



# Cottor Plants (India) Pvt. Ltd.

Certified ISO 9001:2015 Company

**COTTOR** IS PROUD TO HAVE ENTERED INTO TECHNICAL COLLABORATION WITH



**CANTRELL  
WORLDWIDE INC.**

4010 BILLY MITCHELL DR ADDISON • TEXAS • 75006 • USA  
PHONE: +1-972-302-2557 FAX: +1-214-279-0855  
Email: mamizer@cantrellworldwide.com WEB.: www.cantrellworldwide.com

To Manufacture & Supply under licence  
**Latest design, High capacity,  
State of art modern technology,  
Excellent performance,  
Cotton Seed processing machinery & parts  
For Vegetable Oil industries.**

## **NEW ... LARGE CAPACITY TWIN ROLL HULLER ( MODEL - DD # 224 )**



**Twin roll hulling has proven to be the highest capacity and most efficient way to hull bulk oil seeds, which include cottonseed, sunflower, soybean, peanuts, etc.**

Cottor has significantly improved on this technology by Offering the most advanced huller on the market today.

The hulling process starts with an adjustable metered roll feeder designed to offer complete consistency and uniformity to the flow rate. By utilizing an adjustable feed damper and variable speed control, an accurate and reliable feed rate can be maintained.

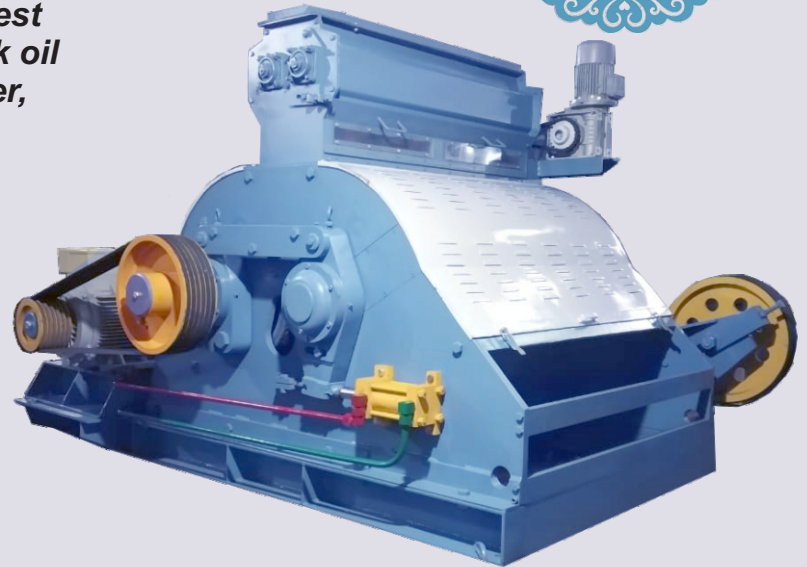

The heart of the hulling process is the twin, rugged rolls equipped with removable huller knives. These twin rolls are driven at a ratio to enhance the cutting process thus minimizing the amount of uncut and recycle seed. This ratio combined with a spiral lead on the cutting edges allows the highest percentage of open "hulled" seed available to the separation room.

### **Features include;**

The replaceable huller knives are manufactured from the highest quality alloy and hardened to above 52R<sup>C</sup> for extra long process life. Having removable hulling surfaces allows Cottor to tailor the knife profiles to fit the specific hulling requirements of the wide variety of oil seeds processed. All huller knives are manufactured from a single fixture giving absolute interchangeability for all replacements.

Protecting the machined huller knives while they are in operation is accomplished with hydraulic cylinders and relief valves that will instantly open the rolls automatically should any damaging contamination come in with the seed stream.

Rugged, reliable, high capacity, low maintenance and economy are the many reasons more processors are changing to Cantrell's twin roll huller.

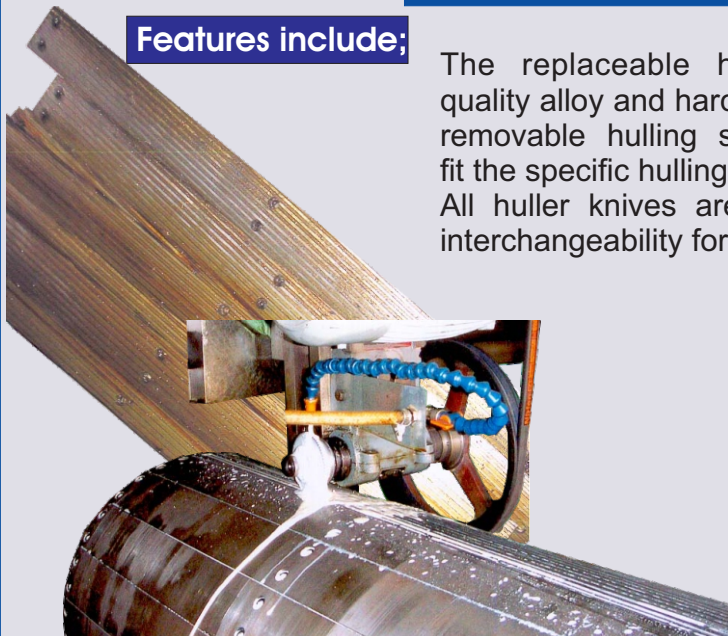

# SPECIFICATIONS: LARGE CAPACITY TWIN ROLL HULLER

1] MAIN DRIVE MOTOR - 40HP 1440 - 415V 50HZ

2] HYDRAULIC MOTOR - 2HP 960 - 440V 50HZ

3] FEEDER MOTOR - 1HP - AC

4] BELTS - PRIMARY B-6 GROOVE - SECONDARY "BB" - 4 GROOVE

5] REPLACEABLE HULLER KNIVES 24 PER CYLINDER 48 TOTAL

6] HYDRAULIC SAFETY ROLL RELIEF SYSTEM

7] SHIPPING WEIGHT: 10140 LBS / 4600 KG

8] SHIPPING VOLUME: 160 FT<sup>3</sup> / 4.5 M<sup>3</sup>

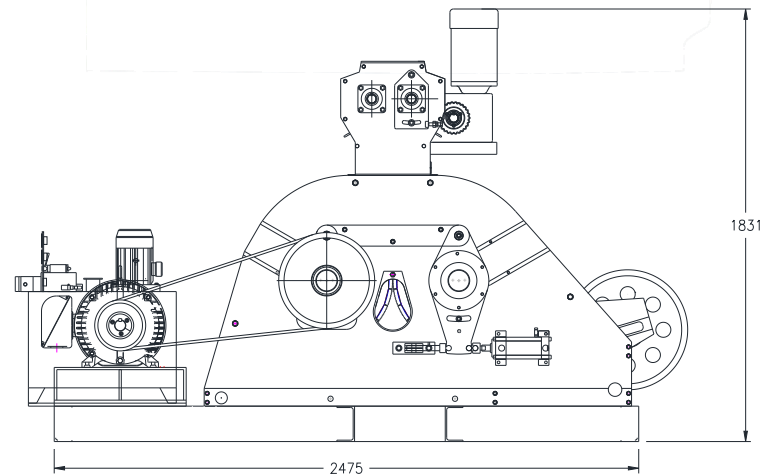
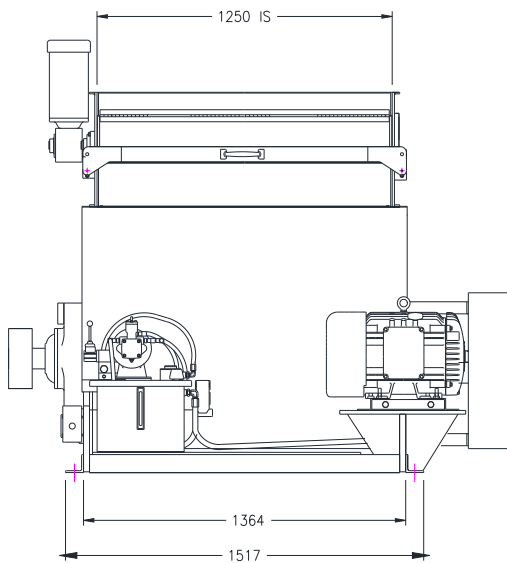
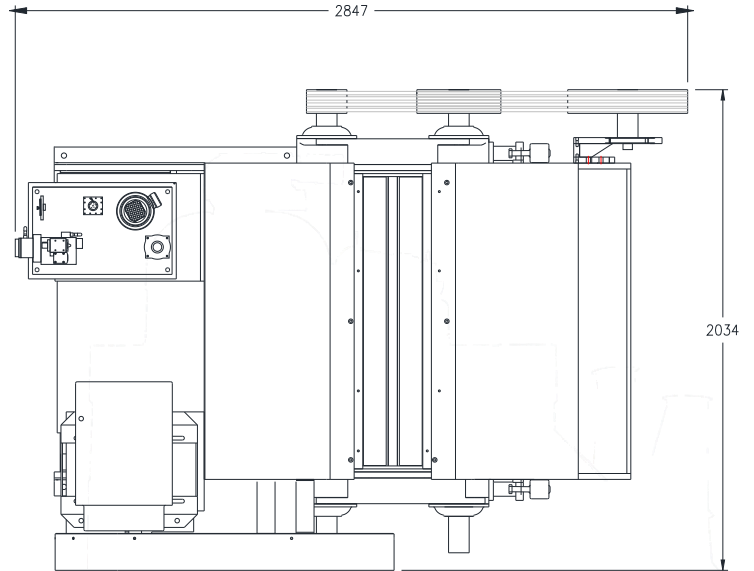
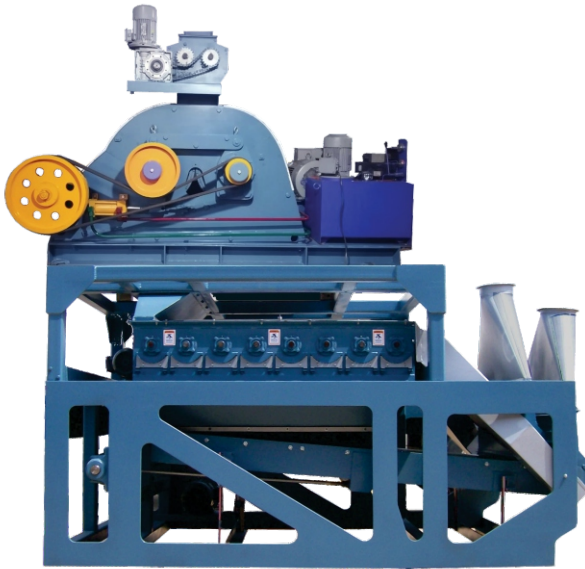

THE LARGE CAPACITY TWIN ROLL HULLER & BASKET BEATER / SHAKER IS PRIMARY TO PRODUCE HULLS WITH A MINIMUM OIL CONTENT BY EFFICIENTLY BEATING THE HULLS TO REMOVE THE HIGH PROTEIN FINISHED MEATS.

THE COMBINATION CONSISTS OF LARGE CAPACITY TWIN ROLL HULLER, NINE-CHAMBER BEATER SECTION MOUNTED ABOVE A SHAKER SEPARATOR TRAY.

WHEN TEAMED UP - you have the most efficient seed hulling & primary removal of hulls from oil bearing seeds on the market today.

## Cottor Plants (India) Pvt. Ltd.

Certified ISO 9001:2015 Company

706, Acme Plaza, Opp. Sangam Talkies, Andheri-Kurla Road, ANDHERI (EAST), MUMBAI - 400059, (INDIA.)  
Tel: +91-22-2826 4201/2/3/4, E-mail: [cottor@vsnl.com](mailto:cottor@vsnl.com), Website: [www.cottor.com](http://www.cottor.com)