



Cottor Plants (India) Pvt. Ltd.

Certified ISO 9001:2015 Company

COTTOR IS PROUD TO HAVE ENTERED INTO TECHNICAL COLLABORATION WITH



**CANTRELL
WORLDWIDE INC.**

4010 BILLY MITCHELL DR ADDISON • TEXAS • 75006 • USA
PHONE: +1-972-302-2557 FAX: +1-214-279-0855
Email: mmizer@cantrellworldwide.com WEB.: www.cantrellworldwide.com

To Manufacture & Supply under licence
**Latest design, High capacity,
State of art modern technology,
Excellent performance,
Cotton Seed processing machinery & parts
For Vegetable Oil industries.**

NEW 7 STAGE LINT CLEANER.

*Utilizing 'Laminar Flow' cleaning,
for the highest recovery of quality
lint in the industry.*

*Extra large capacity reclaim section
for high secondary lint recovery.*

*Beater screens mounted in easy-pull
trays for quick change and ease of
maintenance.*

*Clean rugged design with heavy
structural construction for smooth
operation.*

*Total control of bran, meats and other
oily by-products removed from lint stream.*

*Advanced powdered metal finish for easy
clean-up and long lasting appeal.*



SPECIFICATIONS: 7 STAGE LINT CLEANER

PLAN

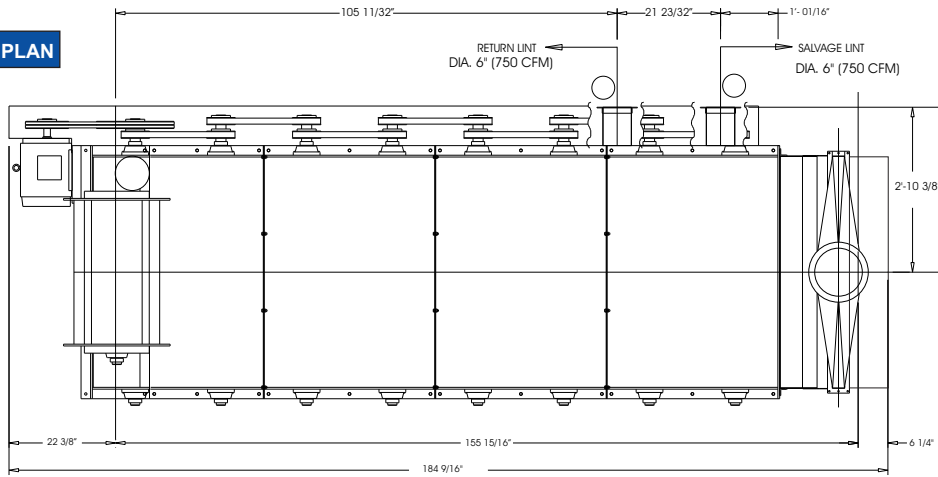

THE COTTOR / CANTRELL 7 STAGE LINT CLEANER WILL PROVIDE THE HIGHEST CAPACITY AND RECOVERY OF LINT ON THE MARKET TODAY, WHILE MAINTAINING THE HIGHEST LINT QUALITY AVAILABLE.

LAMINAR FLOW CLEANING GENTLY FLUFFS THE LINT WHILE REMOVING THE CONTAMINATES WITH LITTLE OR NO DAMAGE TO FIBER.

LARGE PEPPER AND BRAN SECTION ELIMINATES OIL, MEATS, AND HULL BRAN EARLY TO KEEP OIL ABSORPTION AND DISCOLORATION IN FINISHED LINT TO A MINIMUM.

ELEVATION

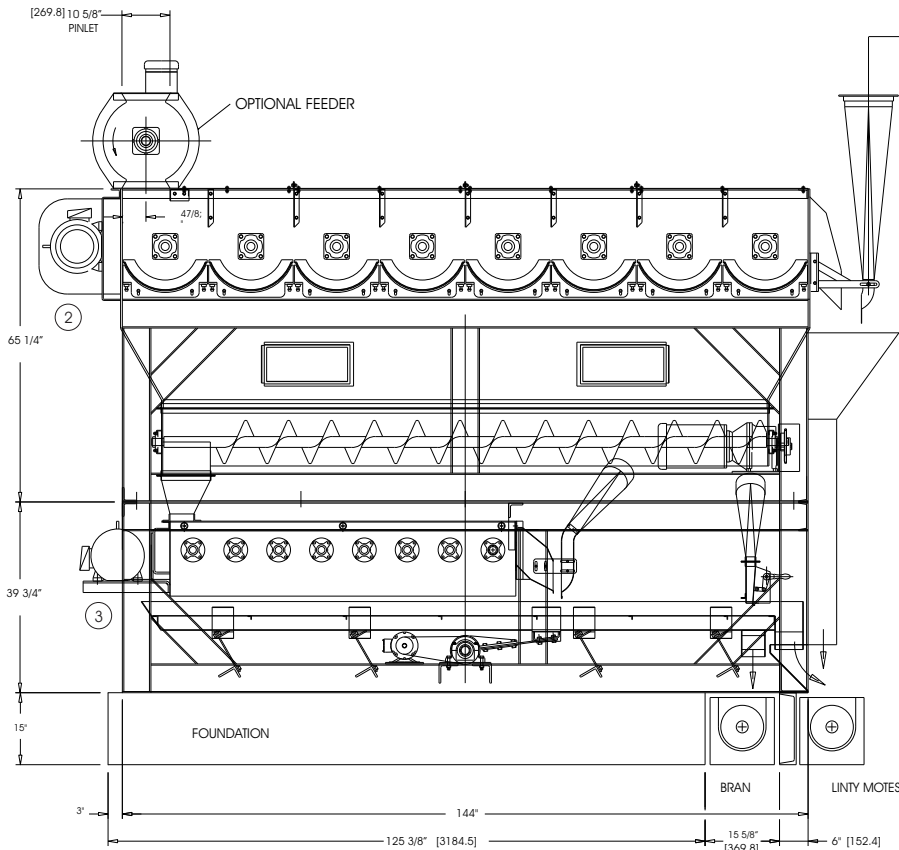

FRONT

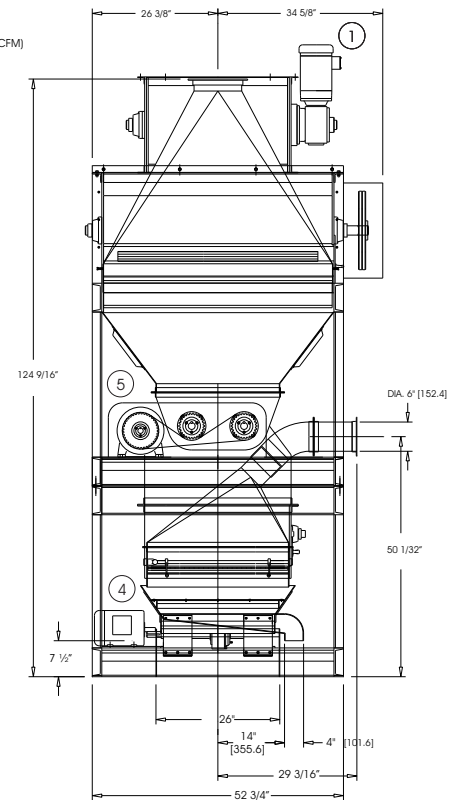

1] FEEDER MOTOR - 1.5HP - 1450/1750RPM - 380/230-460V / 3PH / 50-60HZ

2] BEATER MOTOR - 7.5HP - 1000/1200RPM - 380/230-460V / 3PH / 50-60HZ

3] BEATER MOTOR - 2HP - 1450/1750RPM - 380/230-460V / 3PH / 50-60HZ

4] SHAKER MOTORS - 1HP - 1000/1200RPM - 380/230-460V / 3PH / 50-60HZ

5] TWIN CONVEYOR - 2 HP - 1450/1750 RPM - 380/230-460 V AC, 50-60 HZ

6] AIR HOOD - 10" DIA. / 1600 CFM / 2934 FPM VELOCITY

7] CAPACITY 30,000 LBS / 13,610 KG PER 24 HOUR DAY

8] 48" (1219mm) WIDE CELLULOSE SEC. 30" (762mm) WIDE RECLAIM SEC.

9] SHIPPING WEIGHT: 11,800 LBS / 5,352 KG

10] SHIPPING VOLUME: 603 FT / 17 M

Cottor Plants (India) Pvt. Ltd.

Certified ISO 9001:2015 Company

706, Acme Plaza, Opp. Sangam Talkies, Andheri-Kurla Road, ANDHERI (EAST), MUMBAI - 400059, (INDIA.)
Tel: +91-22-2826 4201/2/3/4, Fax: +91-7303178240, E-mail: cottor@vsnl.com, Website: www.cottor.com