



# Cottor Plants (India) Pvt. Ltd.

Certified ISO 9001:2008 Company

**COTTOR** IS PROUD TO HAVE ENTERED INTO TECHNICAL COLLABORATION WITH



**CANTRELL  
WORLDWIDE INC.**

4010 BILLY MITCHELL DR. ADDISON • TEXAS • 75008 • USA  
PHONE: +1-972-302-2557 FAX: +1-214-279-0855  
Email: mmizer@cantrellworldwide.com WEB: www.cantrellworldwide.com

To Manufacture & Supply under licence  
**Latest design, High capacity,  
State of art modern technology,  
Excellent performance,  
Cotton Seed processing machinery & parts  
For Vegetable Oil industries.**

**NEW...**

## **60" BEATER / SEPARATOR**

**The most efficient primary removal of hulls  
from oil bearing seeds on the market today.**

**The Beater Separator combines  
mechanical and pneumatic forces  
to effectively remove hulls from  
decorticated oil bearing seeds,  
including cottonseed, sunflower,  
soybeans, peanuts, etc.**

**Solidly designed and built for most  
generic hullers to be mounted over  
the frame.**



**Features include:**

**Self cleaning aluminum  
sash for level consistant  
results.**

**Extra heavy duty  
eccentrics for  
smooth operation  
and long life.**

**Beater screens  
mounted in easy-  
pull trays for quick  
change and ease  
of maintenance.**



# SPECIFICATIONS: 60" BEATER / SEPARATOR

## PLAN

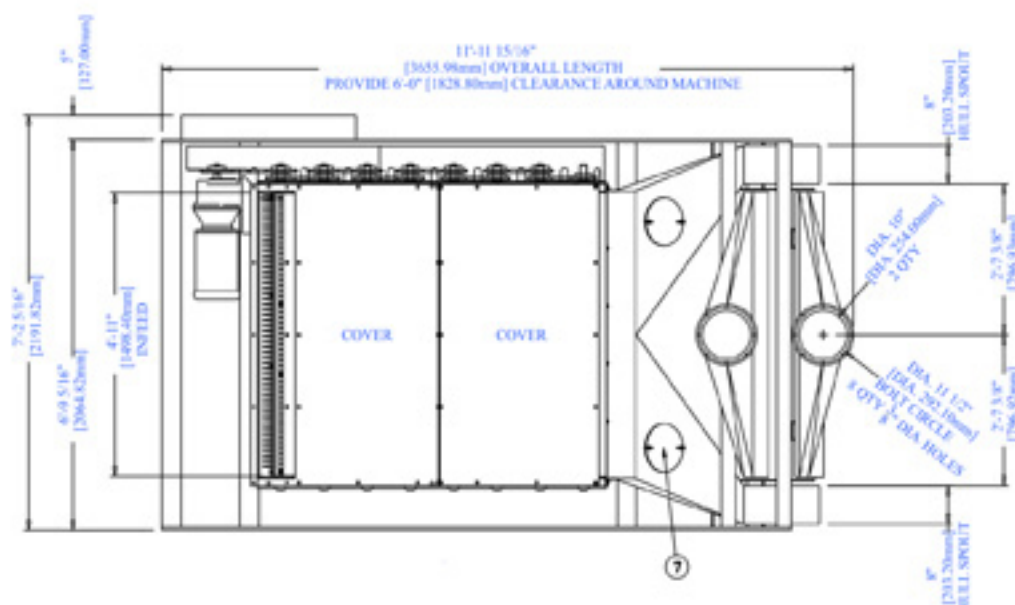

THE COTTOR / CANTRELL BEATER / SHAKER IS PRIMARY TO PRODUCE HULLS WITH A MINIMUM OIL CONTENT BY EFFICIENTLY BEATING THE HULLS TO REMOVE THE HIGH PROTEIN FINISHED MEATS.

THE MACHINE CONSISTS OF AN EIGHT-CHAMBER BEATER SECTION MOUNTED ABOVE A SHAKER SEPARATOR TRAY.

## ELEVATION

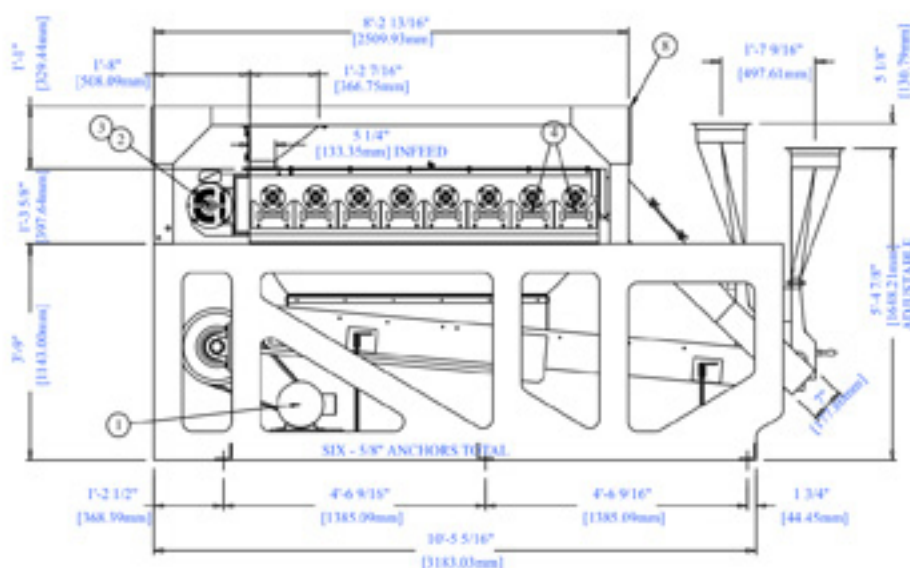

## FRONT

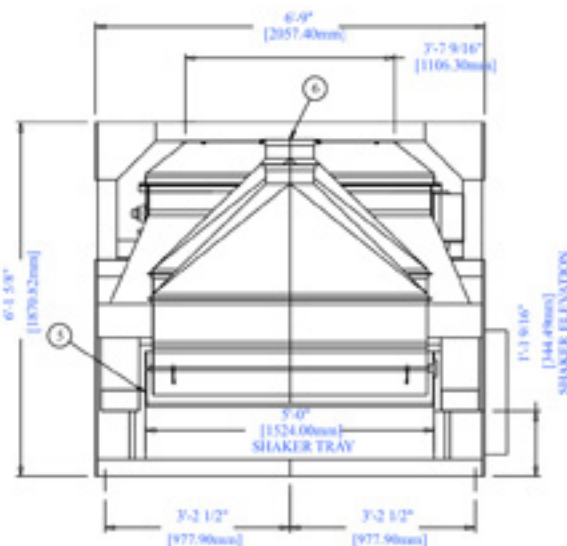

1) SHAKER MOTOR - 2HP-1440/1200 RPM-380/230-440V / 3 PH / 50-60HZ

2) BEATER MOTOR - 5HP - 1450/1750RPM - 380/230-460V / 3PH / 50-60HZ

3) GEAR REDUCER, DOUBLE REDUCTION / HELICAL GEAR

4) 60" EIGHT STATIONARY SCREENS - REMOVABLE

5) SHAKER TRAY - 42.5 SQFT OF SELF CLEANING SASH

6) ADJUSTABLE AIR HOODS - TWO 10" DIA. / 1900 CFM EA. / 3484 FPM

7) INSPECTION WINDOWS - 2 LARGE 10" DIA. VIEWING AREAS

8) UNIVERSAL HULLER STAND / FITS ALL MAKES AND MODELS

9) SHIPPING WEIGHT: 5400 LBS / 2448 KG

10) SHIPPING VOLUME: 512 FT<sup>3</sup> / 14.5 M<sup>3</sup>

## Cottor Plants (India) Pvt. Ltd.

Certified ISO 9001:2008 Company

706, Acme Plaza, Opp. Sangam Talkies, Andheri-Kurla Road, ANDHERI (EAST), MUMBAI - 400059, (INDIA.)

Tel: +91-22-2826 4201/2/3/4, Fax: +91-22-2834 6161, E-mail: [cottor@vsnl.com](mailto:cottor@vsnl.com), Website: [www.cottor.com](http://www.cottor.com)